

PRODUCT BASIC INFORMATION

ENGINEBOX

Marine Sensors for Today and Tomorrow



ENGINEBOX

KEY FEATURES

- 1 x J1939 to NMEA2000 converter.
- 1 x M12 5 pins NMEA2000®.
- 1 x Input 0-4KHz for RPM (2 Inputs with Dual Engine Model).
- 4 x Inputs 0-400 Ohm (up to 8 Inputs with Dual Engine Model).
- 2 x Inputs 4-20 mA .
- 1 x Input 0-5Volt (2 Inputs with Dual Engine Model).
- Analogue to NMEA2000 gateway.
- J1939 to NMEA2000 gateway.
- 2 model for single engine and dual engine configurations.
- Compact design.

The EngineBox expands the possibilities of the NavBox for multi-engine applications or can be used as stand-alone when navigation information is not required. The EngineBox has a NMEA2000® and a J1939 CAN port. The EngineBox can also be used on older, completely analogue engines, thanks to the analogue input ports provided and designed for: RPM data, 0-400 Ohm sensors and 4-20mA sensors.

EngineBox is available in 2 versions: Single Engine and Dual Engine. The Dual Engine version is designed with double frequency and resistive inputs. This allows customers simplified installation wiring, reduced commissioning time and the required installation space.

The EngineBox has to be set up using an intuitive PC Configuration Tool making it easy for programming the inputs (delivered free of charge).

The EngineBox is designed to be installed also in hazardous areas (for additional information please check the technical characteristics described in the installation manual).



TECHNICAL DATA

Housing	Material: Pa6-GF30
Dimensions	WxH: 136 x 130.1 Installation Depth: 41.4 mm
Start-Up Time	Cold Start: < 1 second Warm Start: < 1 second
Operating Voltage	9 -32 VDC
Current Consumption	150mA @ 12V
Operating Temperature	-20°C to 70°C
Storage Temperature	-40°C to 85°C
Protection Class	IEC 60495 exposed (IP69k-f)
Flammability	UL-94 V0
EMC	IEC 60945:2002 / ISO7637-2
Reverse Polarity Protection	Yes
Short Circuit Protection	Yes
Approval	CE, ISO 8846:1990, NMEA2000®
Load Factor	3
Data Input	NMEA2000, J1939, Frequency 0-4KHz, resistive 0-400Ohm. Capacitive 4-20mA, 0-5 Volt
Connector	Delphi Packard Micro-Pack MW100 series, 32Pins
Variants	Single Engine & Dual Engine



CONNECTOR

1x Delphi Packard Micro-Pack MW100 series, 32Pins.

ART. NR. A2C1824820001

SINGLE ENGINE

Pin	Signal
1	Power Supply GND
2	Power Supply GND
3	n.c.
4	Engine Frequency GND
5	NMEA2000: CAN_L
6	NMEA2000: CAN_H
7	NMEA2000: Shield
8	0..400Ohm (1)
9	0..400Ohm (3)
10	0..400Ohm (5)
11	0..400Ohm (7)
12	0..5V (1)
13	n.c.
14	4..20mA
15	n.c.
16	J1939:CAN2_L
17	Power Supply 12/24VDC
18	Ignition
19	n.c.
20	Engine Frequency 1
21	NMEA2000: GND
22	NMEA2000: NET+
23	n.c.
24	n.c.
25	n.c.
26	n.c.
27	0..5V (2)
28	n.c.
29	n.c.
30	4..20mA
31	n.c.
32	J1939:CAN2_L

ART. NR. A2C1767000001

DUAL ENGINE

Pin	Signal
1	Power Supply GND
2	Power Supply GND
3	Engine Frequency 2
4	Engine Frequency GND
5	NMEA2000: CAN_L
6	NMEA2000: CAN_H
7	NMEA2000: Shield
8	0..400Ohm (1)
9	0..400Ohm (3)
10	0..400Ohm (5)
11	0..400Ohm (7)
12	0..5V (1)
13	0..5V (3)
14	4..20mA
15	J1939:CAN3_L
16	J1939:CAN2_L
17	Power Supply 12/24VDC
18	Ignition
19	Engine Frequency 2 GND
20	Engine Frequency 1
21	NMEA2000: GND
22	NMEA2000: NET+
23	0..400Ohm (2)
24	0..400Ohm (4)
25	0..400Ohm (6)
26	0..400Ohm (8)
27	0..5V (2)
28	0..5V (4)
29	Cable Harness Detn.
30	4..20mA
31	J1939:CAN3_H
32	J1939:CAN2_H

DIMENSIONS

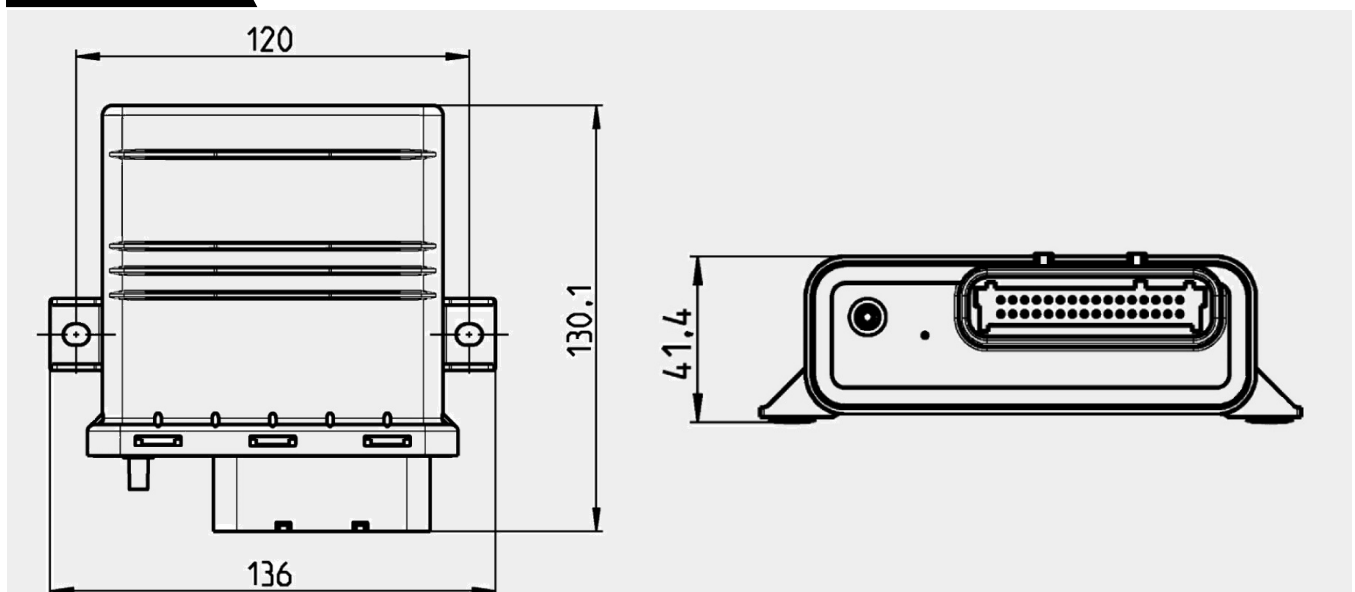

SUPPORTED MESSAGES

SAE J1939 PGN/SPN	Description	NMEA 2000 PGN
PGN61443/92	Engine Percent Load	127488
PGN61444/190	Engine Speed	127488
PGN61444/513	Percentage Torque	127489
PGN65270/102	Engine Turbo Charger Boost Pressure	127489
PGN65262/175	Engine Oil Temperature	127489
PGN65292/110	Engine Coolant Temperature	127489
PGN65271/167	Alternator Potential (Voltage)	127489
PGN65266/183	Engine Fuel Rate	127489
PGN65253/247	Engine Total Hours Operation	127489
PGN65263/109	Engine Coolant Pressure	127489
PGN65263/94	Engine Fuel Delivery Pressure	127489
PGN65263/100	Engine Oil Pressure	127489
PGN65214/189	Engine rate Speed	127498
PGN65260/237	Vehicle Identification Number	127498
PGN65242/234	Software Indication	127498
PGN61445/523	Transmission Current Gear	127493
PGN65272/127	Transmission Oil Pressure	127493
PGN65272/177	Transmission Oil Temperature	127493
PGN65276/96	Fuel Level	127505
PGN65270/173	Exhaust Gas Temperature	130316
PGN65030/2440	Generator Average Line-Line AC RMS Volt	65030
PGN65030/2444	Generator Average Line-Neutral AC RMS Volt	65030
PGN65030/2436	Generator Average Frequency	65030
PGN65030/2448	Generator Average Current	65030

NMEA 2000 SUPPORTED PGNS

Rudder	127245
Engine Speed (rpm)	127448
Engine Parameters Dynamic	127489
Transmission Parameter Dynamic	127493
Fluid Level	127505
Battery Status	127508
Temperature extended Range	130316
Small Craft Status	130576
Generator Average Basic AC Quantities	065030
TX/RX PGN List	126464

ACCESSORIES

A2C96243700	NMEA2000 Cable 0.5m
A2C96243800	NMEA2000 Cable 2m
A2C96244000	NMEA2000 Cable 6m
A2C39312700	NMEA2000 T-Splitter
A2C39312500	NMEA2000 inline terminator



OUTDOOR INSTRUMENTATION ENGINEERED IN SWITZERLAND

Veratron AG / Industriestrasse 18 / 9464 Rüthi / Switzerland
T +41 71 7679 111 / info@veratron.com / veratron.com

The information provided in this brochure contains only general descriptions or performance characteristics, which do not always apply as described in case of actual use or which may change as a result of further development of the products. This information is merely a technical description of the product. It is not meant or intended to be a special guarantee for a particular quality or particular durability. An obligation to provide the respective characteristics shall only exist if expressly agreed in the terms of contract. We reserve the right to make changes in availability as well as technical changes without prior notice.
Veratron AG / English © 2021